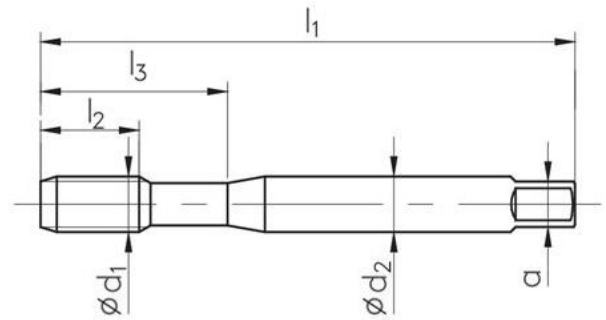

## Gwintownik maszynowy zwykły

 DIN 352  
 ISO 529  
 PN

	<b>M3</b>	<b>M4</b>	<b>M5</b>	<b>M6</b>	<b>M7</b>	<b>M8</b>	<b>M9</b>	<b>M10</b>	<b>M11</b>	<b>M12</b>
<b>L1</b>	48	53	58	66	66	72	72	80	85	89
<b>L2</b>	11	13	16	19	19	22	22	24	25	29
<b>L3</b>	18	21	25	30	30	35	36	39		
<b>d1</b>	3	4	5	6	7	8	9	10	11	12
<b>d2</b>	3,15	4	5	6,3	7,1	8	9	10	8	9
<b>a</b>	2,5	3,15	4	5	5,6	6,3	7,1	8	6,3	7,1

	<b>M14</b>	<b>M16</b>	<b>M18</b>	<b>M20</b>	<b>M22</b>	<b>M24</b>	<b>M27</b>	<b>M30</b>	<b>M33</b>	<b>M36</b>
<b>L1</b>	80	80	95	95	100	110	110	125	125	150
<b>L2</b>	26	27	30	32	32	34	36	40	40	50
<b>L3</b>										
<b>d1</b>	14	16	18	20	22	24	27	30	33	36
<b>d2</b>	11	12	14	16	18	18	20	22	25	28
<b>a</b>	9	9	11	12	14,5	14,5	16	18	20	22

	<b>M39</b>	<b>M42</b>	<b>M45</b>	<b>M48</b>	<b>M52</b>	<b>M56</b>	<b>M60</b>	<b>M64</b>	<b>M68</b>
<b>L1</b>	150	150	160	180	180	180	200	220	220
<b>L2</b>	50	56	58	65	65	70	70	75	75
<b>L3</b>									
<b>d1</b>	39	42	45	48	52	56	60	64	68
<b>d2</b>	32	32	36	36	40	40	45	50	50
<b>a</b>	24	24	29	29	32	32	35	39	39